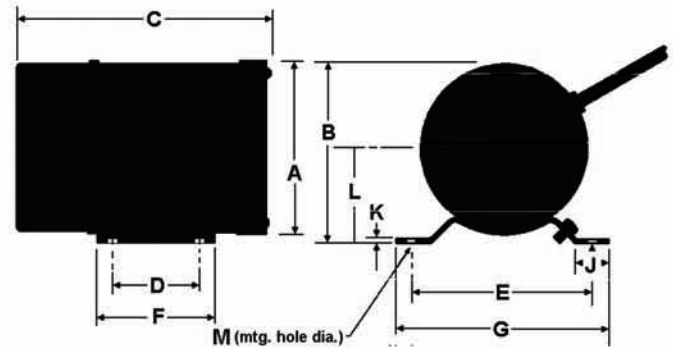

Table of Contents

3600 RPM Single Phase 115/1/60	page 3
3600 RPM 2-Pole, 230/460 Volt, 3-Phase, 60 Cycle	page 4
1800 RPM 4-Pole, 230/460 Volt, 3-Phase, 60 Cycle	page 5
1200 RPM 6-Pole, 230/460 Volt, 3-Phase, 60 Cycle	page 6
900 RPM 8-Pole, 230/460 Volt, 3-Phase, 60 Cycle	page 7
Design Features	page 8
Installation	page 9
Amplitude & Force Requirements	page 9
Mounting	page 9
Channel Reinforcement for Hoppers, Bins & Chutes	page 10
Proper Welding	page 10
Vibrator Location	page 11
Fasteners	page 11
Force Output Adjustment	page 12
Proper Grounding	page 12
Fuse/Overload Protection	page 12
Local Electrical Codes	page 12
Terminal Connection	page 13
Amperage Draw	page 13
Cables and Power Leads	page 13
Maintenance	page 14
Bearing Maintenance	page 14
Bearing Life	page 14
Lubrication Comments	page 14
Bearings Lubrication	page 15
Construction	page 17
Table 1 - Single Phase (3600 RPM)	page 17
Table 2 - Three Phase (3600 RPM)	page 17
Table 4 - Three Phase (1800 RPM)	page 17
Table 4 - Three Phase (1200 RPM)	page 18
Table 5 - Three Phase (900 RPM)	page 17
Diagrams	page 19
Customer Receipt & Storage	page 21
Periodical Inspection	page 21
Troubleshooting	page 22
Guarantee	page 23



- Operates Off Standard 115/1/60 Power
- Continuous Duty Rated
- Totally Enclosed, Dust Tight Housing
- Capacitor Starter Supplied with Each Unit
- Quiet Operating, Less Than 60 dba
- 0-100% Force Adjustment



Drawing A

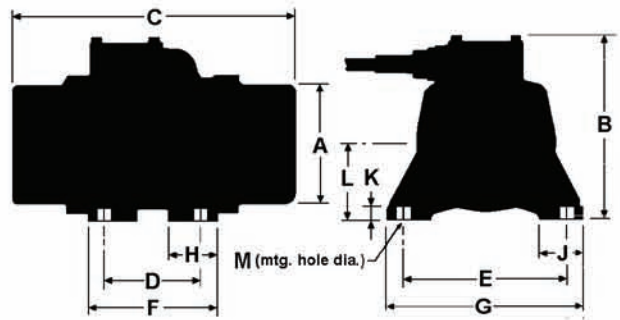

Drawing B

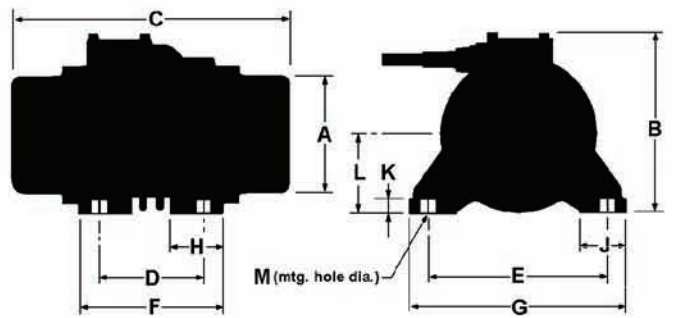

Drawing C

MODEL	DIRECT REPLACEMENT	H.P.	MAX FORCE (lbs.)	DRWG. REF.	DIMENSIONS (inches)												FULL LOAD AMPS AT 115v.	WT. (lbs.)	UNBALANCE (inch-lbs.)
					A	B	C	D	E	F	G	H	J	K	L	M			
SEE-0.1-2	BES-30-2	1/50	30	A	3-11/32	3-7/16	5-5/16	1-47/64	3-35/64	2-3/8	4-7/32	—	23/32	3/32	1-25/32	11/32	0.39	6	0.100
SEE-0.5-2	BES-110-2	1/25	110	B	4-19/64	6-5/8	8	1-9/16	4-11/16	2-3/4	5-21/32	—	1-9/32	29/64	2-29/64	7/16	0.53	14	0.318
SEE-1-2	BES-220-2	1/12	220	B	4-5/32	6-5/16	8-15/32	3-5/32	5-1/8	4-11/32	6-5/16	1-19/32	1-15/32	13/32	2-5/8	15/32	1.2	22	0.636
SEE-2-2	BES-440-2	1/6	440	B	4-11/32	6-29/32	9-15/32	3-35/64	5-29/32	4-23/32	7-3/32	1-25/32	1-19/32	15/32	2-13/16	9/16	1.9	30	1.27
SEE-3.5-2	BES-770-2	1/3	770	C	4-15/16	7-11/16	11-13/16	4-21/64	7-31/64	5-29/32	9-1/16	2-3/16	2-31/32	19/32	3-5/16	23/32	2.9	45	2.22

• Models SEE-0.5-2 through SEE-3.5-2 are factory preset at 100% of maximum force. They are totally adjustable by a single setting change on the eccentric weights. Force output for the SEE-0.1-2 is not adjustable.

• Capacitor and overload protection for the SEE-0.5-2 through SEE-3.5-2 are provided in a NEMA 12 enclosure, offered for each unit. Model SEE-0.1-2 has the capacitor built into the motor itself.

3600 RPM 2-Pole, 230/460 Volt, 3-Phase, 60 Cycle

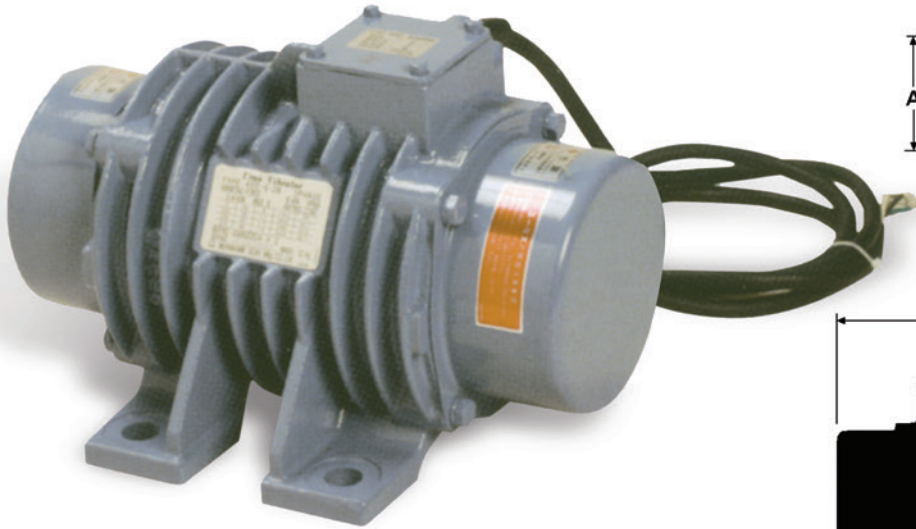

- Dust Tight Design
- Ideal for Bins, Hoppers and Chutes
- High Force to Motor Weight Ratio
- Heavy Duty Design for Mounting in any Position
- Ideal for Concrete and Refractory Applications

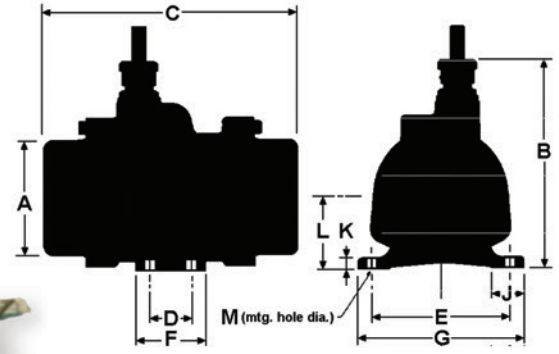

Drawing A

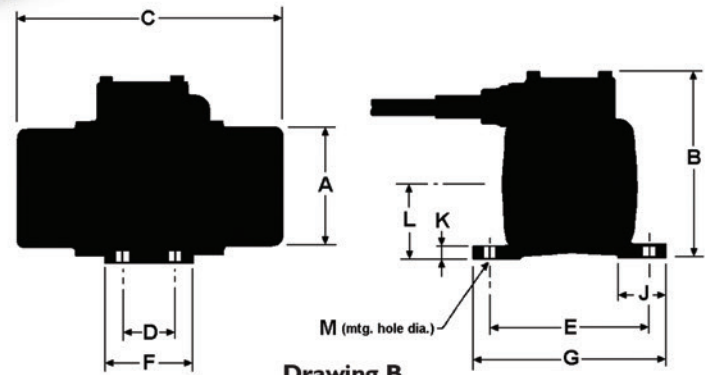

Drawing B

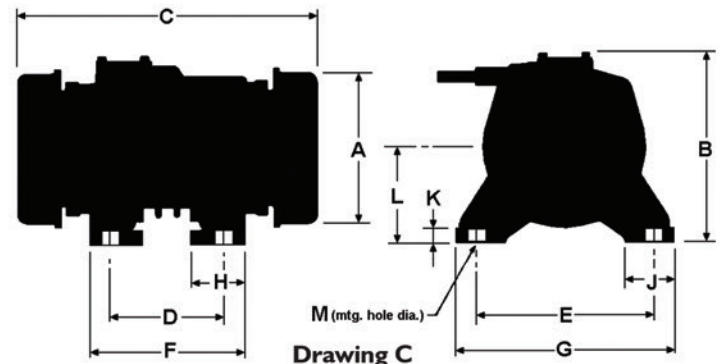

Drawing C

MODEL	DIRECT REPLACEMENT	H.P.	MAX FORCE (lbs.)†	DRWG. REF.	DIMENSIONS (inches)											FULL LOAD AMPS AT		WT. (lbs.)	UNBALANCE (inch-lbs.)	
					A	B	C	D	E	F	G	H	J	K	L	M	115v.			460v.
KEE-0.5-2*	BE-110-2*	1/20	110	A	4-19/64	5-55/64	8	1-9/16	4-11/16	2-3/4	5-21/32	—	1-9/32	29/64	2-29/64	7/16	0.33	0.15	10	0.32
KEE-1-2	BE-220-2	1/10	220	B	4-19/64	5-55/64	8	1-9/16	4-11/16	2-3/4	5-21/32	—	1-9/32	29/64	2-29/64	7/16	0.41	0.25	15	0.64
KEE-2-2	BE-220-2	1/5	440	C	4-19/64	5-55/64	9	1-9/16	4-11/16	2-3/4	5-21/32	1-9/32	1-15/32	25/64	2-29/64	7/16	0.62	0.35	20	1.27
KEE-3.5-2	BE-770-2	1/3	770	C	4-11/32	6-29/32	10-7/16	3-35/64	5-29/32	4-23/32	7-3/32	1-25/32	1-19/32	15/32	2-15/16	9/16	1.1	0.6	35	2.22
KEE-6-2	BE-1320-2	1/2	1,320	C	4-15/16	7-11/16	11-13/16	4-21/64	7-31/64	5-29/32	9-1/16	2-3/16	1-31/32	19/32	3-5/16	23/32	1.6	0.9	55	3.82
KEE-10-2	BE-2200-2	1	2,200	C	6-11/16	8-9/32	13-25/32	4-23/32	8-21/32	6-11/16	10-5/8	2-9/16	1-3/8	23/32	3-5/8	13/16	2.7	1.4	78	6.36
KEE-16-2	BE-3520-2	1-1/2	3,520	C	6-11/16	10-1/4	16-17/32	5-33/64	9-29/64	7-7/8	11-13/16	2-31/32	2-3/4	13/16	5-1/16	1-1/32	4.0	2.0	110	10.20
KEE-23-2	BE-5060-2	2-1/4	5,060	C	7-1/2	11-1/32	17-23/32	5-29/32	10-15/64	8-9/32	12-19/32	3-5/32	2-3/4	13/16	5-19/32	1-1/32	5.6	2.9	140	14.60
KEE-30-2	BE-6600-2	3	6,600	C	8-7/8	12-19/32	19-11/16	6-11/16	12-13/64	9-7/16	14-31/32	3-3/4	3-11/32	1-1/8	6-7/32	1-5/16	7.0	3.6	210	19.10
KEE-40-2	BE-8800-2	4	8,800	C	8-7/8	4-19/32	22-1/16	8-21/32	13-25/32	11-13/16	16-15/16	—	3-15/16	1-5/16	7-9/32	1-17/32	9.8	4.9	290	25.40

- 3600 RPM motors are dual voltage, either 230 volt or 460 volt 3-phase. Specify voltage when ordering. 575 volt available on special order.
- 50 cycle motors are available for all 3600 RPM motors. Consult factory for pricing and availability.
- † Factory preset at 100% of maximum force. All units are totally adjustable by a simple setting change on the eccentric weights.
- * Available in 460 volt only.

1800 RPM 4-Pole, 230/460 Volt, 3-Phase, 60 Cycle

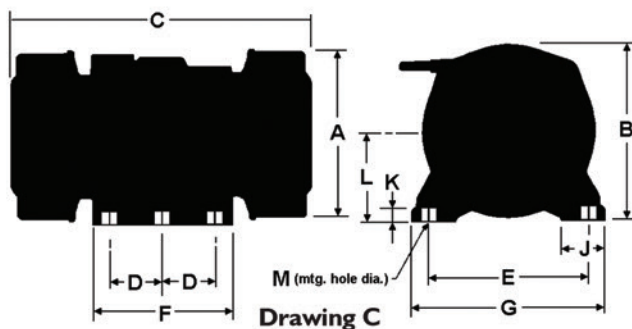
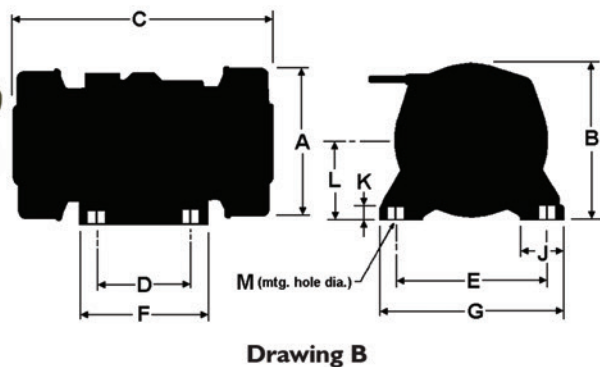
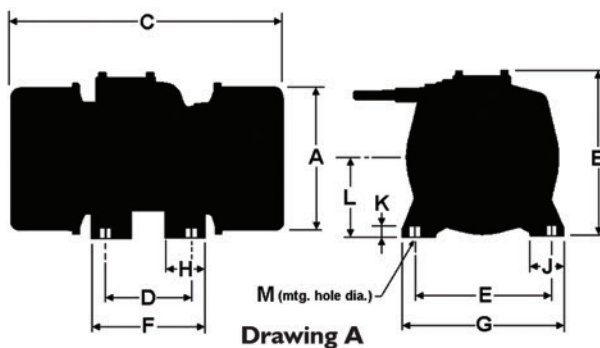
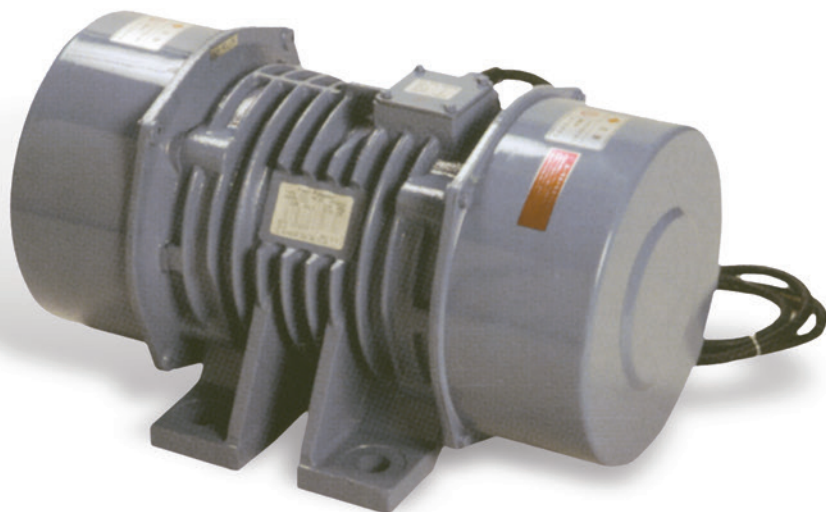

- For Bins and Hoppers Requiring Greater Amplitude
- For Vibrating Tables, Feeders and Screeners
- Continuous Duty Rated at Maximum Force
- 1/10 HP to 10 HP Size Range

MODEL	DIRECT REPLACEMENT	H.P.	MAX FORCE (lbs.)†	DRWG. REF.	DIMENSIONS (inches)											FULL LOAD AMPS AT		WT. (lbs.)	UNBALANCE (inch-lbs)	
					A	B	C	D	E	F	G	H	J	K	L	M	230v.			460v.
KEE-1.5-4	BE-330-4	1/10	330	A	4-19/64	5-55/64	10	1-9/16	4-11/16	2-3/4	5-21/32	1-9/32	1-3/16	25/64	2-29/64	7/16	0.50	0.33	25	3.82
KEE-3-4	BE-660-4	1/6	660	A	6-1/8	7-3/32	10-5/8	3-5/32	5-29/32	4-11/32	7-3/32	1-19/32	1-3/8	13/32	3-5/16	15/32	0.80	0.52	35	7.63
KEE-6-4	BE-1320-4	1/3	1,320	A	6-11/16	7-11/16	12-19/32	3-15/16	6-19/64	5-1/8	7-1/2	1-25/32	1-19/32	15/32	3-5/8	9/16	1.2	0.70	50	15.3
KEE-9-4	BE-1980-4	1/2	1,980	A	7-1/2	8-9/32	13-3/8	4-21/64	7-3/32	5-29/32	8-21/32	2-3/16	1-31/32	19/32	4-1/32	23/32	1.7	0.99	70	22.9
KEE-12-4	BE-2640-4	4/5	2,640	A	8-7/8	9-15/32	14-3/16	5-33/64	8-21/32	7-1/2	10-5/8	2-9/16	2-3/8	23/32	4-23/32	7/8	2.5	1.4	95	30.5
KEE-17-4	BE-3740-4	1-1/10	3,740	A	9-21/32	10-1/4	16-17/32	5-33/64	9-29/64	7-7/8	11-13/16	2-31/32	2-3/4	7/8	5-1/8	1-1/32	3.0	1.6	125	43.2
KEE-24-4	BE-5280-4	1-1/2	5,280	A	10-7/16	11-1/32	18-29/32	5-29/32	10-15/64	8-9/32	12-19/32	3-5/32	2-3/4	7/8	5-19/32	1-1/32	3.8	2.0	165	61.0
KEE-34-4	BE-7480-4	2	7,480	A	11-5/8	12-19/32	20-7/8	6-11/16	12-13/64	9-15/32	14-31/32	3-3/4	3-11/32	1-1/8	6-7/32	1-5/16	5.0	2.6	245	86.5
KEE-52-4	BE-11440-4	3	11,440	B	13-19/32	14-3/8	23-7/32	8-21/32	13-25/32	11-13/16	16-15/16	—	3-15/16	1-5/16	7-9/32	1-17/32	7.7	4.0	375	132
KEE-75-4	BE-16500-4	5	16,500	C	15-9/16	16-11/32	24-13/16	4-59/64	14-31/32	13-1/32	18-1/8	—	4-5/32	1-5/16	8-9/32	1-17/32	12.3	6.2	495	191
KEE-84-4	BE-18480-4	7-1/2	18,480	C	15-9/16	16-11/32	26-3/8	4-59/64	14-31/32	13-1/32	18-1/8	—	4-5/32	1-5/16	8-9/32	1-17/32	18.2	9.4	565	214
KEE-110-4	BE-24200-4	10	24,200	C	18-5/16	18-23/32	28-3/4	5-33/64	17-21/64	14-9/16	20-7/8	—	4-15/16	1-1/2	9-15/32	1-25/32	25	13	805	280

- 1800 RPM motors are dual voltage, either 230 volt or 460 volt 3-phase. Specify voltage when ordering. 575 volt available on special order.
- All 1800 RPM motors are rated for continuous duty at the maximum force setting.

- 50 cycle motors are available for all 1800 RPM motors. Consult factory for pricing and availability.
- † Factory preset at 100% of maximum force. All units are totally adjustable by a simple setting change on the eccentric weights.

1200 RPM 6-Pole, 230/460 Volt, 3-Phase, 60 Cycle

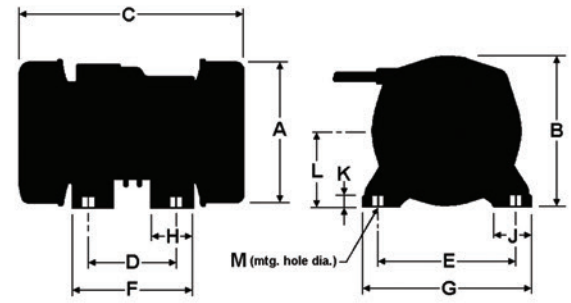

Drawing A

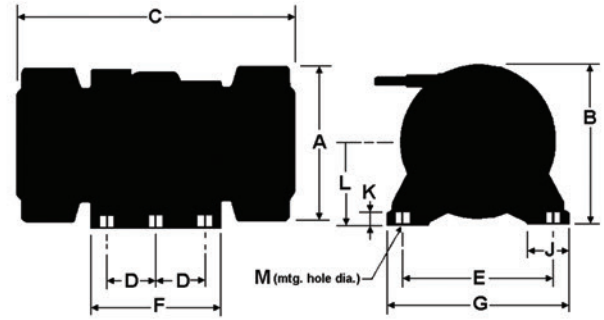

Drawing B

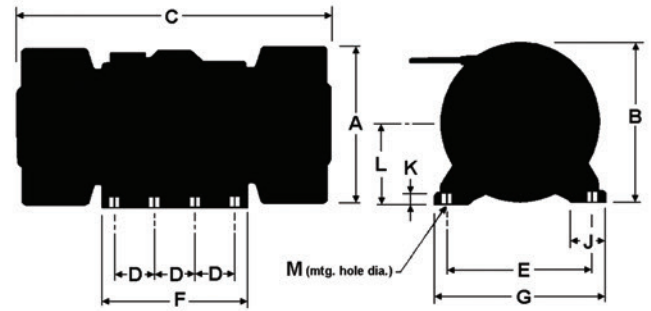

Drawing C

- For Large Feeders, Tables and Screeners
- High Amplitude, Low Frequency Design
- 1/4 HP to 17-1/2 HP Size Range
- 0-100% Force Adjustment
- Continuous Duty Rated at Maximum Force

MODEL	DIRECT REPLACEMENT	H.P.	MAX FORCE (lbs.)†	DRWG. REF.	DIMENSIONS (inches)													FULL LOAD AMPS AT		WT. (lbs.)	UNBALANCE (inch-lbs.)
					A	B	C	D	E	F	G	H	J	K	L	M	230v.	460v.			
KEE-3-6	BE-660-6	1/4	660	A	6-11/16	7-11/16	11-7/16	3-15/16	6-19/64	5-1/8	7-1/2	1-25/32	1-9/32	15/32	3-5/8	9/16	1.1	0.65	49	17.2	
KEE-5-6	BE-1100-6	1/2	1,100	A	7-1/2	8-9/32	13	4-21/64	7-3/32	5-29/32	8-21/32	2-3/16	1-31/32	19/32	4-1/32	23/32	1.9	1.3	71	28.6	
KEE-9-6	BE-1980-6	4/5	1,980	A	8-7/8	9-15/32	14-9/16	5-33/64	8-21/32	7-1/2	10-5/8	2-9/16	2-3/8	23/32	4-23/32	13/16	2.7	1.6	104	51.5	
KEE-13-6	BE-2860-6	1-1/10	2,860	A	9-21/32	10-1/4	15-3/8	5-33/64	9-29/64	7-7/8	11-13/16	2-31/32	2-3/4	13/16	5-1/8	1-1/32	3.7	2.1	139	74.4	
KEE-18-6	BE-3960-6	1-1/2	3,960	A	10-7/16	11-1/32	17-23/32	5-29/32	10-15/64	8-9/32	12-19/32	3-5/32	2-3/4	13/16	5-19/32	1-1/32	4.8	2.7	185	103	
KEE-24-6	BE-5280-6	2	5,280	A	11-5/8	12-19/32	19-11/16	6-11/16	12-13/64	9-15/32	14-31/32	3-3/4	3-11/32	1-1/8	6-7/32	1-5/16	6.1	3.3	265	137	
KEE-34-6	BE-7480-6	3	7,480	A	13-19/32	14-3/8	22-7/16	8-21/32	13-25/32	11-13/16	16-15/16	—	3-15/16	1-5/16	7-9/32	1-17/32	7.9	4.2	364	195	
KEE-45-6	BE-9900-6	4	9,900	A	13-19/32	14-3/8	24-13/16	8-21/32	13-25/32	11-13/16	16-15/16	—	3-15/16	1-5/16	7-9/32	1-17/32	10.8	5.7	448	258	
KEE-60-6	BE-13200-6	5-1/3	13,200	B	15-9/16	16-11/32	24-13/16	4-59/64	14-31/32	13	18-1/8	—	4-5/32	1-5/16	8-9/32	1-17/32	13.4	7.4	567	343	
KEE-80-6	BE-17600-6	7-1/2	17,600	B	15-9/16	16-11/32	28-47/64	4-59/64	14-31/32	13	18-1/8	—	4-5/32	1-5/16	8-9/32	1-17/32	18.5	10	662	458	
KEE-110-6	BE-24200-6	10	24,200	B	18-5/16	18-23/32	29-15/16	5-33/64	17-21/64	14-9/16	20-7/8	—	4-15/16	1-1/2	9-15/32	1-25/32	27	15	924	630	
KEE-140-6	BE-30800-6	12	30,800	C	20-9/32	20-11/16	34-21/32	5-33/64	18-29/32	20-3/32	22-7/16	—	4-15/16	1-1/2	10-7/16	1-25/32	31	17	1268	801	
KEE-165-6	BE-36300-6	15	36,300	C	20-9/32	20-11/16	36-39/64	5-33/64	18-29/32	20-3/32	22-7/16	—	4-15/16	1-1/2	10-7/16	1-25/32	37	20	1389	944	
KEE-185-6	BE-40700-6	17-1/2	40,700	C	22-1/16	22-7/16	36-7/32	5-33/64	20-15/32	20-3/32	24-1/32	—	4-15/16	1-1/2	11-7/16	1-25/32	44	22	1599	1059	

- 1200 RPM motors are dual voltage, either 230 volt or 460 volt 3-phase. Specify voltage when ordering. 575 volt available on special order.
- All 1200 RPM motors are rated for continuous duty at the maximum force setting.
- 50 cycle motors are available for all 1200 RPM motors. Consult factory for pricing and availability.
- † Factory preset at 100% of maximum force. All units are totally adjustable by a simple setting change on the eccentric weights.

900 RPM 8-Pole, 230/460 Volt, 3-Phase, 60 Cycle

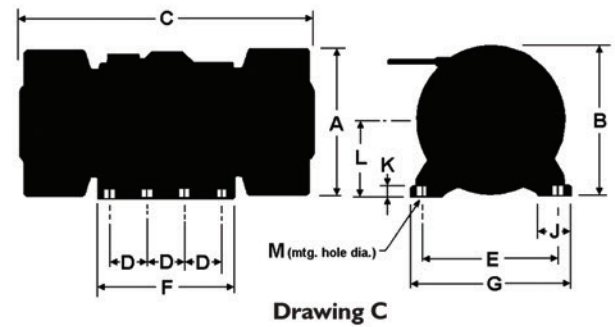
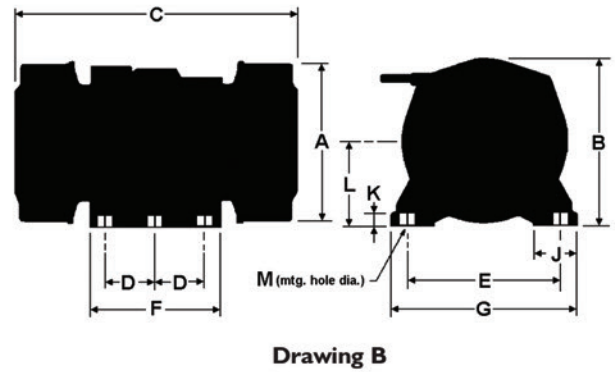
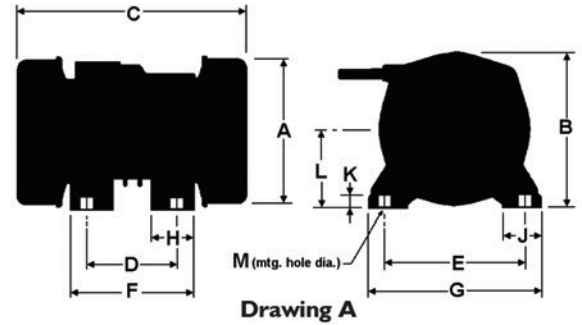
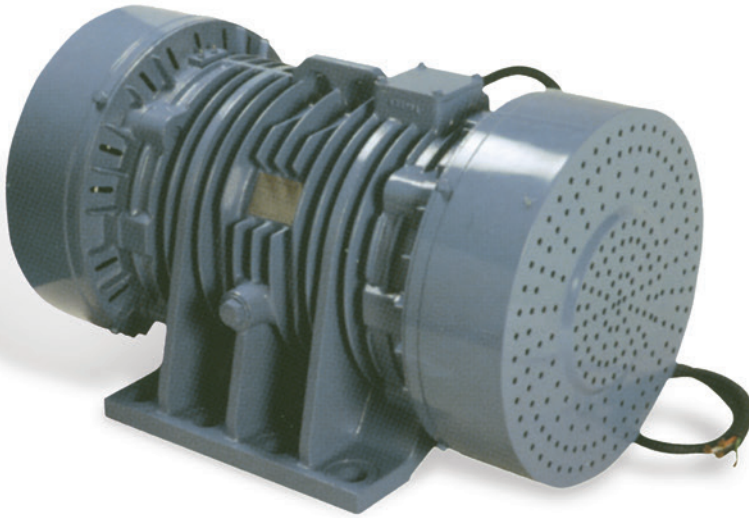

- Ideal Shakeout Vibrator for Foundries
- High Capacity Feeder Drive
- Suitable Drive for Large Screeners
- Replace Old Belt Driven Type Shaker Drives
- Quiet Operating, Dust Tight, Continuous Duty Rated

MODEL	DIRECT REPLACEMENT	H.P.	MAX FORCE (lbs.)†	DRWG. REF.	DIMENSIONS (inches)													FULL LOAD AMPS AT 230v. 460v.		WT. (lbs.)	UNBALANCE (inches-lbs.)
					A	B	C	D	E	F	G	H	J	K	L	M					
KEE-5-8	BE-1100-8	1/2	1,100	A	8-7/8	9-15/32	14-9/16	5-33/64	8-21/32	7-1/2	10-5/8	2-9/16	2-3/8	23/32	4-23/32	13/16	2.4	1.5	100	50.9	
KEE-7.3-8	BE-1606-8	4/5	1,606	A	9-21/32	10-1/4	15-3/8	5-33/64	9-29/64	7-7/8	11-13/16	2-31/32	2-3/4	13/16	5-1/8	1-1/32	3.3	2.0	130	74.3	
KEE-10-8	BE-220-8	1	2,200	A	10-7/16	11-1/32	17-23/32	5-29/32	10-15/64	8-9/32	12-19/32	3-5/32	2-3/4	13/16	5-19/32	1-1/32	4.9	3.3	175	102.0	
KEE-20-8	BE-440-8	2	4,400	A	11-5/8	12-19/32	21-21/32	6-11/16	12-13/64	9-15/32	14-31/32	3-3/4	3-11/32	1-1/8	6-7/32	1-5/16	7.5	4.4	300	203.0	
KEE-35-8	BE-7710-8	3	7,700	A	13-19/32	14-3/8	26-3/8	8-21/32	13-25/32	11-13/16	16-15/16	—	3-15/16	1-5/16	7-9/32	1-17/32	9.5	5.5	465	356.0	
KEE-42-8	BE-9240-8	4	9,240	A	13-19/32	14-3/8	28-3/4	8-21/32	13-25/32	11-13/16	16-15/16	—	3-15/16	1-5/16	7-9/32	1-17/32	9.5	5.5	486	403.0	
KEE-60-8	BE-13200-8	5	13,200	B	15-9/16	16-11/32	28-3/4	4-59/64	14-31/32	13-7/8	18-1/8	—	4-5/32	1-5/16	8-9/32	1-17/32	14.6	8.6	660	610.0	
KEE-77-8	BE-16940-8	6	16,940	B	15-9/16	16-11/32	32-3/4	4-59/64	14-31/32	13-7/8	18-1/8	—	4-5/32	1-5/16	8-9/32	1-17/32	15	7.5	803	783.0	
KEE-100-8	BE-22000-8	8	22,000	B	18-5/16	18-23/32	33-7/8	5-33/64	17-21/64	14-9/16	20-7/8	—	4-15/16	1-1/2	9-15/32	1-25/32	25	15	1070	1017.0	
KEE-125-8	BE-27500-8	10	27,500	C	20-9/32	20-11/16	39-3/8	5-33/64	18-29/32	20-3/32	22-7/16	—	4-15/16	1-1/2	10-7/16	1-25/32	31	18	1420	1272.0	
KEE-150-8	BE-33000-8	12	33,000	C	20-9/32	20-11/16	40-15/16	5-33/64	18-29/32	20-3/32	22-7/16	—	4-15/16	1-1/2	10-7/16	1-25/32	37	22	1560	1526.0	
KEE-185-8	BE-40700-8	15	40,700	C	22-1/16	22-7/16	39-3/4	5-33/64	20-15/32	20-3/32	24-1/32	—	4-15/16	1-1/2	11-7/16	1-25/32	43	26	1800	1882.0	

- 900 RPM motors are dual voltage, either 230 volt or 460 volt 3-phase. Specify voltage when ordering. 575 volt available on special order.
- All 900 RPM motors are rated for continuous duty at the maximum force setting.

- 50 cycle motors are available for all 1200 RPM motors. Consult factory for pricing and availability.
- † Factory preset at 100% of maximum force. All units are totally adjustable by a simple setting change on the eccentric weights.

Design Features

- 53 different models
- Frequency ranges: 3600, 1800, 1200 & 900 rpm
- Horsepower ranges: 1/50 to 17-1/2 hp
- Force output: 30 lbs. to 40,000 lbs.
- Explosion-proof options available

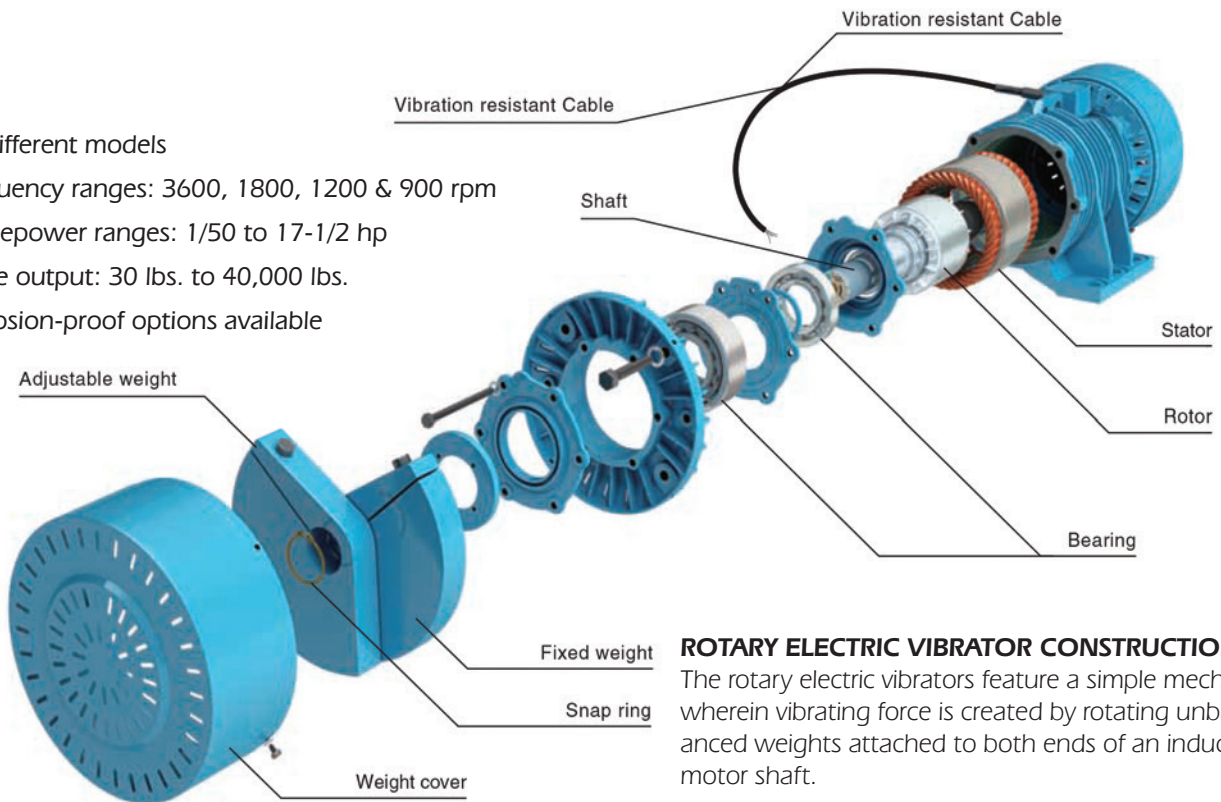

ROTARY ELECTRIC VIBRATOR CONSTRUCTION

The rotary electric vibrators feature a simple mechanism wherein vibrating force is created by rotating unbalanced weights attached to both ends of an induction motor shaft.

HEAVY DUTY CONSTRUCTION

Guarantees long life and excellent field performance. Ductile iron castings, steel end covers and high alloy fasteners are just some of the unique design features. All units can be mounted horizontally or vertically.

LONG LIFE BEARINGS

Insure peak, long-term performance. The B-10 bearing life is unsurpassed in the industry. The smaller units are furnished with ball bearings which are sealed for the life of the bearing, Larger units employ both ball and roller bearings with grease fittings.

0% TO 100% FORCE ADJUSTMENT

Available on all but the smallest model. Many competitive units offer models with limited "continuous duty" force settings. All SEE and KEE models are rated for continuous duty at maximum force.

THE HIGHEST FORCE TO MOTOR WEIGHT RATIO

Industry leader.

LOW NOISE LEVEL

All motors average 55 db(A) as measured five feet from the motor.

DUST TIGHT CONSTRUCTION AND SPLASHPROOF DESIGN

suitable for dusty, dirty environments, as well as outdoors in rain and snow.

TERMINAL JUNCTION BOX AND CABLE

Assembled with compression type Belleville locking washers to prevent loosening by vibrator.

AMPLITUDE & FORCE REQUIREMENTS

Amplitude (inches)

Force (pounds)

Frequency (RPM/motor)

Load (pounds)

Equal to structure weight, plus motor weight, plus material or product weight.

$$\text{AMPLITUDE} = 70,500 \times \frac{\text{FORCE}}{\text{LOAD} \times (\text{FREQUENCY})^2}$$

$$\text{FORCE REQUIRED} = \frac{\text{AMPLITUDE} \times \text{LOAD} \times (\text{FREQUENCY})^2}{70,500}$$

NOTE: The actual frequencies, vibrator weights, and force figures needed for the above calculations can be obtained from data charts in this brochure.

MOUNTING

Improper mounting of the motor vibrator can result in damage to the bin, hopper or fabricated chute or can cause an excessive amperage draw on the motor vibrator. Care must be taken to provide a sufficiently rigid mounting structure to withstand the force and frequency being generated by the vibrator.

All electric vibrators, especially those being installed outdoors, should be mounted so that the terminal box is facing the ground or floor. This prevents possible moisture from accumulating on the surface of the terminal or junction box. Rotary electric vibrators should be installed with their shaft parallel to the ground and the rotary motion as shown in the diagram. After the unit has been electrically connected, check rotation. If rotation is incorrect, reverse the polarity on the power leads to the motor.

For typical equipment installations with twin motors, be certain that larger motors which must be mounted with the rotational axis vertical, are oriented with the proper end down. These larger motors have one roller bearing at one end and both a roller and a ball bearing at the opposite end. The ball bearing end must be in the down position to handle the axial thrust loading. Motors are marked "under-side" when end-for-end orientation must be maintained.

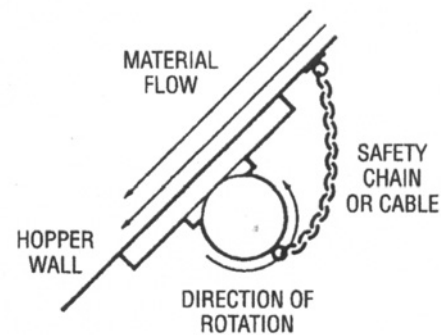

NOTE

To prevent injury from falling vibrator, install a safety cable on all installations.

CHANNEL REINFORCEMENT FOR HOPPERS, BINS & CHUTES

When applying BPS Motor Vibrators to a hopper or bin, refer to wall reinforcement diagrams shown below. Our vibrator motors are designed to bolt to a rigid channel with angle or channel stiffeners approximately 3' to 6' long located on either side. This mounting method will distribute the vibratory energy evenly across the wall while allowing easy access to bolts and nuts.

BPS stocks a standard "MC" mounting channel for each size of motor vibrator. Please consult factory for further details.

IMPORTANT

Never bolt vibrator directly to hopper wall without reinforcement channel. Warranty will be voided if this occurs.

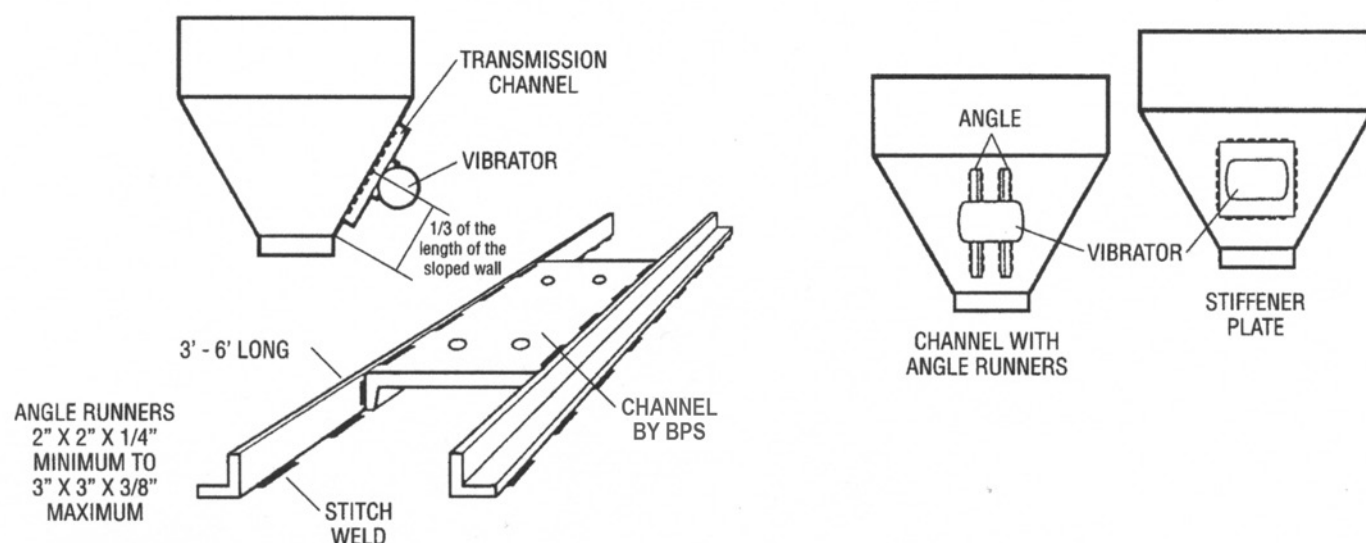

PROPER WELDING

The first rule in attaching a mounting channel for a vibrator is to never continuous weld. Continuous welding creates brittleness in the fabricated bin or hopper wall. Regardless of whether a stiffener plate or channel is used, stitch welding should always be employed leaving proper temper and strength in the bin wall between welds. A stitch weld one or two inches with an equal space between welds of one or two inches should be employed.

VIBRATOR LOCATION

Most bin or hopper applications will require only one KEE rotary electric vibrator. BPS recommends mounting the single drive as indicated in figure 1, locating the unit at the point on the sloped wall section that is one-third up the sloping wall.

Applications involved with particularly stubborn material or larger hoppers may require two or more vibrators. The recommended mounting is shown in figures 2 and 3. Normally, not more than three vibrators would ever be required on a conical hopper or bin, and a maximum of four on a four-sided bin.

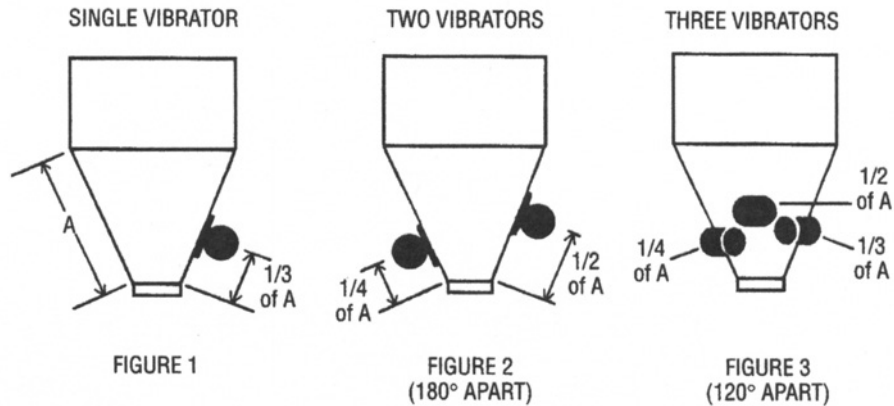

FASTENERS

Bolt the motor vibrator to the channel or mounting bracket with fasteners as shown in the diagram below.

NOTE

Always use grade 5 hex head, fine thread bolts with locking (nylon interference) type lock nuts and a high strength compression or belleville washer.

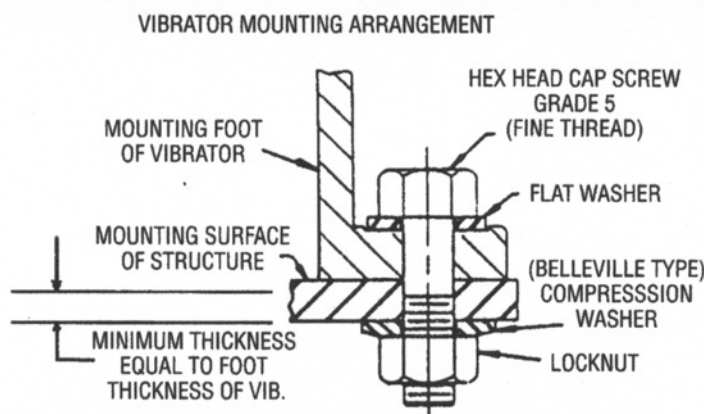

NOTE: REFER TO CHART SHOWN FOR PROPER TORQUE VALUE FOR SIZE BOLT EMPLOYED

IMPORTANT

Always retighten bolts after the first hour of service in order to take up initial bolt stretch. Recheck again periodically for the next several days to avoid bolt loosening. Be certain that a safety cable is employed, where injury might be caused by a falling motor due to the loosening of fasteners, (refer to drawing on previous page.)

Grade 5 Bolt Specs	Nut Torque Specs
Thread Size	Torque (Ft-Lb)
1/4 - 28	8 - 10
5/16 - 24	15 - 19
3/8 - 24	35 - 39
7/16 - 20	57 - 61
1/2 - 20	83 - 93
9/16 - 18	107 - 117
5/8 - 18	168 - 178
3/4 - 16	290 - 300
7/8 - 14	475 - 485
1 - 14	685 - 695
1 1/4 - 7	840 - 1120
1 1/2 - 6	1462 - 1949
1 3/4 - 5	2806 - 3074

FORCE OUTPUT ADJUSTMENT

All BPS vibrator motors are factory set at a maximum force output. To decrease the centrifugal force output, a quick and easy adjustment can be made to the eccentric weight position at each end of the motors.

1. Disconnect all power to the unit.
2. Remove both end covers, exposing the eccentric weights. Notice that each end of the shaft has a percentage calibration from 0% to 100%. (See photo illustration.)
3. Loosen the outer eccentric weight at each end of the motor with a metric wrench. Rotate the dot (punch mark) to the desired force output percentage position at both ends of the motor.
4. Be certain weights have been retightened securely and replace end covers back in their proper position.

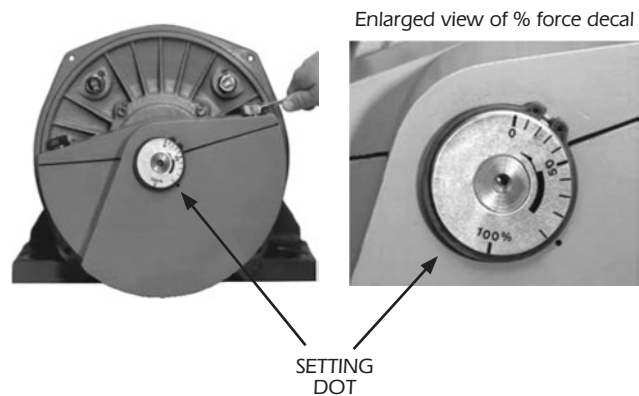

IMPORTANT

- Both ends of the motor must be adjusted to the same setting.
- Never loosen the inside eccentric weights, closest to the motor.
- Be certain eccentric weights are retightened securely.

PROPER GROUNDING

The ground lead (marked E) on the four lead cable, is green in color, and is connected through the terminal box and into the vibrators main body. Make certain this lead is properly grounded to prevent electrical shock and possible injury.

FUSE/OVERLOAD PROTECTION

KEE Models

All Model "KEE" motors require a proper protective overload circuit. If the unit is not operated with the proper overload protection (heaters), all factory warranties are null and void. BPS offers both a magnetic and an in-line manual starter with overload protection. This starter or a factory approved equal is required.

SEE Models

All "SEE" Models except the SEE-.1-2, require a 115/1/60 capacitor starter in order to operate. Direct power to the SEE motor without going thru a BPS capacitor starter may cause permanent motor damage. Only the SEE-.1-2 model has a built in capacitor in the motor housing. Under no circumstances should model SEE-.5-2 thru SEE-3.5-2 be wired directly to a 115/1/60 power source.

LOCAL ELECTRICAL CODES

BPS assumes no liability for local electrical codes. The consumer is responsible for meeting requirements of all local electrical codes.

TERMINAL CONNECTION

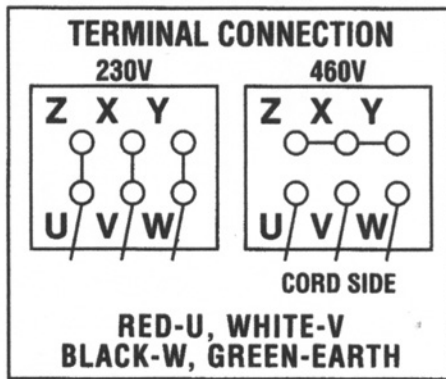

AMPERAGE DRAW

After a qualified electrician has made all electrical connections, test the motor vibrator for proper amperage draw against the nameplate data. A lower amp draw than what is stated on the nameplate is acceptable, especially at lower eccentric weight settings. Avoid excessive or high amperage draw, otherwise the motor will “burn” out. Should the motor draw excessive amps, one of two things must be done immediately.

1. Reduce the eccentric weight setting.
OR
2. Reinforce the bin wall or fabricated device to which the motor is attached.

IMPORTANT

Running a vibrator motor at an amp draw above nameplate rating voids any warranty.

CABLE AND POWER LEADS

Never permit the power cable to bend sharply at the junction box outlet of the motor vibrator. The drawings and table below indicate the minimum permissible radius (R) for the model of vibrator selected for your application.

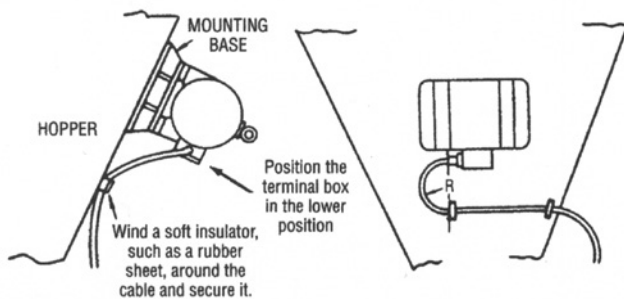

BPS Model No.	Minimum Radius(R)
SEE-0.1-2 to SEE-3.5-2	3"
KEE-0.5-2 to KEE-23-2	3"
KEE-1.5-4 to KEE-24-4	3"
KEE-3-6 to KEE-18-6	3"
KEE-5-8 to KEE-10-8	3"
KEE-30-2 to KEE-40-2	4"
KEE-34-4 to KEE-52-4	4"
KEE-24-6 to KEE-45-6	4"
KEE-20-8 to KEE-35-8	4"
KEE-75-4 to KEE-110-4	5"
KEE-60-6 to KEE-110-6	5"
KEE-60-8 to KEE-100-8	5"
KEE-140-6 to KEE-185-6	7"
KEE-125-8 to KEE-185-8	7"

BEARING MAINTENANCE

BPS recommends the use of Shell Oil's Alvania Grease #3 as a bearing lubricant. This is a special lubricant designed for motor vibrator bearings and similar applications where shock is involved.

Alternate greases are Shell's #2 and Mobil Oil's Mobilux #2 or #3.

Many of the motor vibrators incorporate sealed bearings. No grease fitting will appear on the vibrator housing if a sealed bearing is being used. These bearings are factory lubricated for the life of the bearing. When the bearing life expires on these models, simply replace the bearing entirely.

BEARING LIFE

The expected life for the bearings of all motor vibrators is 5,000 hours (min.) for 2 pole types, and 10,000 hours (min) for 4, 6, and 8 pole types.

LUBRICATION COMMENTS

1. The grease tables that follow indicate the amount of grease to be employed at each regreasing period. **DO NOT EXCEED THIS AMOUNT.** Excessive grease can cause resistance. Small amounts of grease at more frequent intervals is best.
2. Immediately after greasing the bearing, the temperature may rise slightly. After approximately one hour of operation, the temperature will return to normal.
3. Grease resistance and life of the bearing can be affected by atmospheric temperature changes. Refer to the table below for the correct amount of lubrication.

Environmental Temperature in Degrees Fahrenheit	Amount of Grease Recommended
24 to 33 °F	25% of normal amount
34 to 50 °F	50% of normal amount
51 to 65 °F	75% of normal amount
66 °F or higher	100% of normal amount

Model	Old Model	Bearings (Quantity x Type)	Maintenance		
			Amount of grease to be added per bearing (g)	Grease supply intervals (hrs)	Amount of grease applied at factory (g)
SEE-0.1-2	BES-30-2B	2 x 6200 ZZC3	NO LUBRICATION NEEDED		
SEE-0.5-2	BES-110-2C	2 x 6201 ZZC3			
SEE-1-2	BES-220-2B	2 x 6202 ZZC4			
SEE-2-2	BES-440-2B	2 x 6303 ZZC4			
SEE-3.5-2	BES-770-2B	2 x 6305 ZZC4			
KEE-0.5-2	BE-110-2C	2 x 6202 ZZC4			
KEE-1-2	BE-220-2C	2 x 6202 ZZC4			
KEE-2-2	BE-440-2C	2 x 6203 ZZC4			
KEE-3.5-2	BE-770-2B	2 x 6305 ZZC4			
KEE-6-2	BE-1320-2B	2 x 6306 ZZC4			
KEE-10-2	BE-2200-2B	2 x 6407 ZZC4			
KEE-16-2	BE-3520-2B	2 x NJ 309 EC3	10	700	25
KEE-23-2	BE-5060-2B	2 x NJ 310 EC3	12	600	30
KEE-30-2	BE-660-2B	2 x NJ 312 EC3	15	450	40
KEE-40-2	BE-8800-2B	2 x NJ 313 EC3	20	400	50
KEE-1.5-4	BE-330-4B	2 x 6203 ZZC4	NO LUBRICATION NEEDED		
KEE-3-4	BE-6600-4B	2 x 6304 ZZC4			
KEE-6-4	BE-1320-4B	2 x 6306 ZZC4			
KEE-9-4	BE-1980-4B	2 x 6308 ZZC4			
KEE-12-4	BE-2640-4B	2 x 6309 ZZC4			
KEE-17-4	BE-3740-4B	2 x NJ 309 EC3	10	1600	25
KEE-24-4	BE-5280-4B	2 x NJ 310 EC3	12	1400	30
KEE-34-4	BE-7480-4B	2 x NJ 312 EC3	15	1200	40
KEE-52-4	BE-11440-4B	2 x NJ2314 EC3	30	1100	65
KEE-75-4	BE-16500-4B	2 x NJ 2316 EC3	40	900	90
KEE-84-4	BE-18480-4B	2 x NJ 2318 EC3	50	700	110
KEE-110-4	BE-24200-4B	2 x NJ 2320 EC3	40	400	140
		1 x 6620	15	400	60
KEE-3-6	BE-660-6B	2 X 6305 ZZC4	NO LUBRICATION NEEDED		
KEE-5-6	BE-1100-6B	2 X 6306 ZZC4			
KEE-9-6	BE-1980-6B	2 X 6308 ZZC4			
KEE-13-6	BE-2860-6B	2 X 6309 ZZC4			
KEE-18-6	BE-3960-6B	2 X 6312 ZZC4			
KEE-24-6	BE-5280-6B	2 X 6314 ZZC4			

Maintenance

Model	Old Model	Bearings (Quantity x Type)	Maintenance		
			Amount of grease to be added per bearing (g)	Grease supply intervals (hrs)	Amount of grease applied at factory (g)
KEE-34-6	BE-7480-6B	2 x NJ 312 EC3	15	2000	40
KEE-45-6	BE-9900-6B	2 x NJ 314 EC3	20	1800	40
KEE-60-6	BE-13200-6B	2 x NJ 316 EC3	30	1500	65
KEE-80-6	BE-17600-6B	2 x NJ 2318 EC3	50	1400	110
KEE-110-6	BE-24200-6B	2 x NJ 2320 EC3	65	1200	140
		1 x 6620	25	1200	60
KEE-140-6	BE-30800-6B	2 x NJ 2322 EC3	80	1100	175
		1 x 6222	30	1100	80
KEE-165-6	BE-36300-6B	2 x NJ 2324 EC3	90	900	200
		1 x 6224	35	900	90
KEE-185-6	BE-40700-6B	2 x NJ 2326 EC3	105	800	250
		1 x 6226	40	800	100
KEE-5-8	BE-1100-8B	2 x 6306 ZZC4	NO LUBRICATION NEEDED		
KEE-7.3-8	BE-1606-8B	2 x 6307 ZZC4			
KEE-10-8	BE-2200-8B	2 x 6308 ZZC4			
KEE-20-8	BE-4400-8B	2 x 6312 ZZC4			
KEE-35-8	BE-7700-8B	2 x NJ 313 EC3	20	2500	50
KEE-42-8	BE-9240-8B	2 x NJ 314 EC3	20	2500	50
KEE-60-8	BE-13200-8B	2 x NJ 316 EC3	30	2200	65
KEE-77-8	BE-16940-8B	2 x NJ 2318 EC3	50	2200	110
KEE-100-8	BE-22000-8B	2 x NJ 2320 EC3	65	1900	140
		1 x 6220	25	1900	60
KEE-125-8	BE-27500-8B	2 x NJ2322 EC3	80	1600	175
		1 x 6222	30	1600	80
KEE-150-8	BE-33000-8B	2 x NJ2324 EC3	90	1500	200
		1 x 6224	35	1500	90
KEE-185-8	BE-40700-8B	2 x NJ 2326 EC3	105	1400	250
		1 x 6226	40	1400	100

The following tables are categorized by the frequency of the motor vibrator. There are seven basic construction diagrams. Locate the model of your motor vibrator and refer to the appropriate construction diagram for that model. Diagrams of the motor along with a parts list are located on the following pages.

TABLE 1 - SINGLE PHASE (3600 RPM)

Model	Old Model	Maximum Force (lbs)	Amp. Draw		Construction	
			(110v)		Diagram	Reference
SEE-.1-2	BES-30-2B	30	0.39		Figure 1	Page 19
SEE-.5-2	BES-110-2C	110	0.53		Figure 1	Page 19
SEE-1-2	BES-220-2B	220	1.20		Figure 1	Page 19
SEE-2-2	BES-440-2B	440	1.90		Figure 1	Page 19
SEE-3.5-2	BES-770-2B	770	2.90		Figure 1	Page 19

TABLE 2 - THREE PHASE (3600 RPM)

Model	Old Model	Maximum Force (lbs)	Amp. Draw		Construction	
			(230v)	(460v)	Diagram	Reference
KEE-.5-2	BE-110-2C	110	0.33	0.15	Figure 1	Page 19
KEE-1-2	BE-220-2C	220	0.41	0.25	Figure 1	Page 19
KEE-2-2	BE-440-2C	440	0.62	0.35	Figure 1	Page 19
KEE-3.5-2	BE-770-2B	770	1.10	0.60	Figure 1	Page 19
KEE-6-2	BE-1320-2B	1,320	1.60	0.90	Figure 1	Page 19
KEE-10-2	BE-2200-2B	220	2.70	1.40	Figure 2	Page 19
KEE-16-2	BE-3520-2B	3,520	4.00	2.00	Figure 5	Page 20
KEE-23-2	BE-5060-2B	5,060	5.60	2.90	Figure 5	Page 20
KEE-30-2	BE-6600-2B	6,600	7.00	3.60	Figure 5	Page 20
KEE-40-2	BE-8800-2B	8,800	9.80	4.90	Figure 5	Page 20

TABLE 3 - THREE PHASE (1800 RPM)

Model	Old Model	Maximum Force (lbs)	Amp. Draw		Construction	
			(230v)	(460v)	Diagram	Reference
KEE-1.5-4	BE-330-4B	330	0.50	0.33	Figure 3	Page 19
KEE-3-4	BE-660-4B	660	0.80	0.52	Figure 3	Page 19
KEE-6-4	BE-1320-4B	1,320	1.20	0.70	Figure 3	Page 19
KEE-9-4	BE-1980-4B	1,980	1.70	0.99	Figure 3	Page 19
KEE-12-4	BE-2640-4B	2,640	2.50	1.40	Figure 3	Page 19
KEE-17-4	BE-3740-4B	3,740	3.00	1.60	Figure 6	Page 20
KEE-24-4	BE-5280-4B	5,280	3.80	2.00	Figure 6	Page 20
KEE-34-4	BE-7480-4B	7,480	5.00	2.60	Figure 6	Page 20
KEE-52-4	BE-11440-4B	11,440	7.70	4.00	Figure 7	Page 20
KEE-75-4	BE-16500-4B	16,500	12.30	6.20	Figure 7	Page 20
KE-84-4	BE-18480-4B	18,480	18.20	9.40	Figure 7	Page 20
KE-110-4	BE-24200-4B	24,200	25.00	13.00	Figure 7	Page 20

TABLE 4 - THREE PHASE (1200 RPM)

Model	Old Model	Maximum Force (lbs)	Amp. Draw		Construction	
			(230v)	(460v)	Diagram	Reference
KEE-3-6	BE-660-6B	660	1.10	0.65	Figure 3	Page 19
KEE-5-6	BE-1100-6B	1,100	1.90	1.30	Figure 3	Page 19
KEE-9-6	BE-1980-6B	1,980	2.70	1.60	Figure 3	Page 19
KEE-13-6	BE-2860-6B	2,860	3.70	2.10	Figure 3	Page 19
KEE-18-6	BE-3960-6B	3,960	4.80	2.70	Figure 4	Page 19
KEE-24-6	BE-5280-6B	5,280	6.10	3.30	Figure 4	Page 19
KEE-34-6	BE-7480-6B	7,480	7.90	4.20	Figure 6	Page 20
KEE-45-6	BE-9900-6B	9,900	10.80	5.70	Figure 7	Page 20
KEE-60-6	BE-13200-6B	13,200	13.40	7.40	Figure 7	Page 20
KEE-80-6	BE-17600-6B	17,600	18.50	10.00	Figure 7	Page 20
KEE-110-6	BE-24200-6B	24,200	27.00	15.00	Figure 7	Page 20
KEE-140-6	BE-30800-6B	30,800	31.00	17.00	Figure 7	Page 20
KEE-165-6	BE-36300-6B	36,300	37.00	20.00	Figure 7	Page 20
KEE-185-6	BE-40700-6B	40,700	44.00	22.00	Figure 7	Page 20

TABLE 5 - THREE PHASE (900 RPM)

Model	Old Model	Maximum Force (lbs)	Amp. Draw		Construction	
			(230v)	(460v)	Diagram	Reference
KEE-5-8	BE-1100-8B	1,100	2.40	1.50	Figure 3	Page 19
KEE-7.3-8	BE-1606-8B	1,606	3.30	2.00	Figure 3	Page 19
KEE-10-8	BE-2200-8B	2,200	4.90	3.30	Figure 3	Page 19
KEE-20-8	BE-4400-8B	4,400	7.50	4.40	Figure 3	Page 19
KEE-35-8	BE-7700-8B	7,700	9.50	5.50	Figure 6	Page 20
KEE-42-8	BE-9240-8B	9,240	9.20	5.50	Figure 6	Page 20
KEE-60-8	BE-13200-8B	13,200	14.60	8.60	Figure 7	Page 20
KEE-77-8	BE-16940-8B	16,940	15.30	9.00	Figure 7	Page 20
KEE-100-8	BE-22000-8B	22,000	25.00	15.00	Figure 7	Page 20
KEE-125-8	BE-27500-8B	27,500	31.00	18.00	Figure 7	Page 20
KEE-150-8	BE-33000-8B	33,000	37.00	22.00	Figure 7	Page 20
KEE-185-8	BE-40700-8B	40,700	43.00	26.00	Figure 7	Page 20

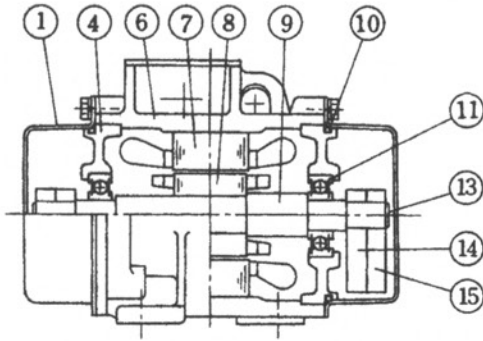

FIGURE 1

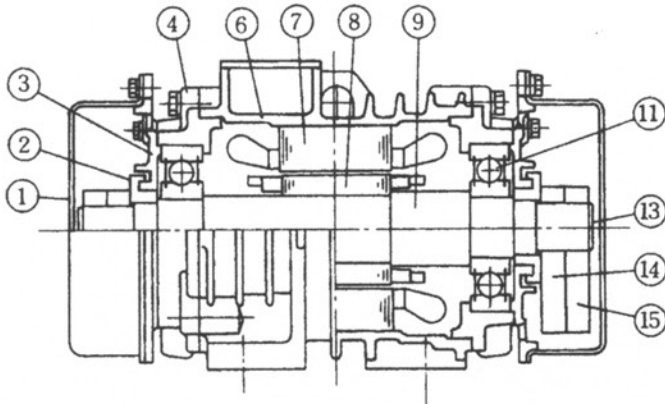

FIGURE 2

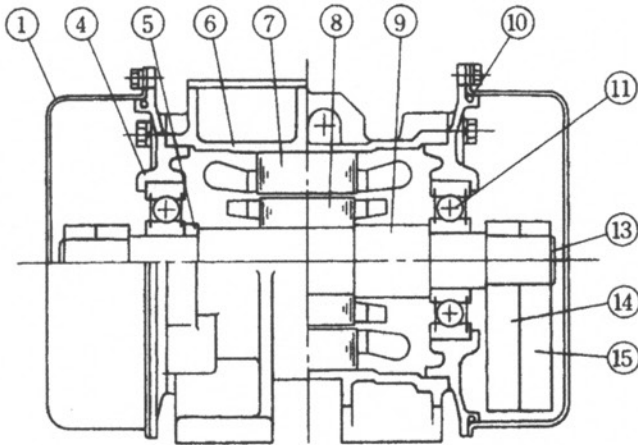

FIGURE 3

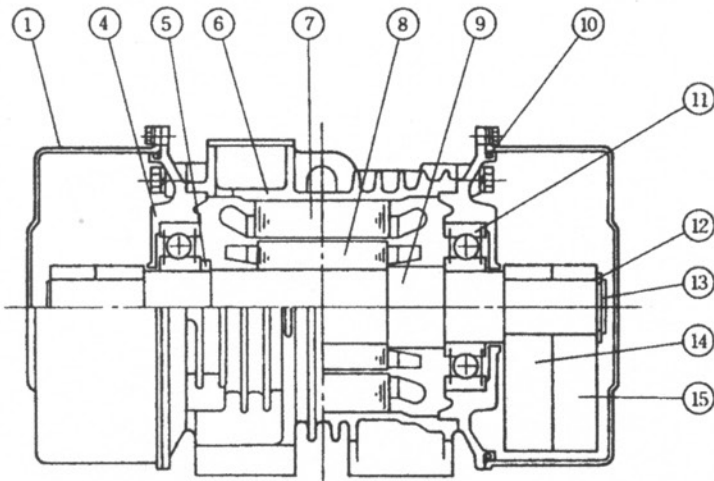

FIGURE 4

No.	Part Name
1	Weight Cover
2	Dust Collar
3	Bearing Cover
4	Bracket
5	Collar
6	Frame
7	Stator Core
8	Rotor Core
9	Shaft
10	Seal Ring
11	Ball Bearing
12	Snap Ring
13	Scale Plate
14	Fixed Weight
15	Adjustable Weight

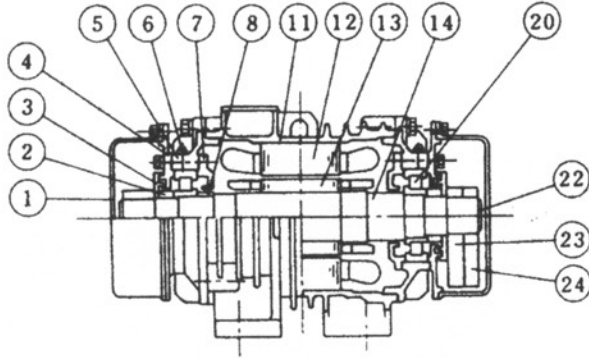

FIGURE 5

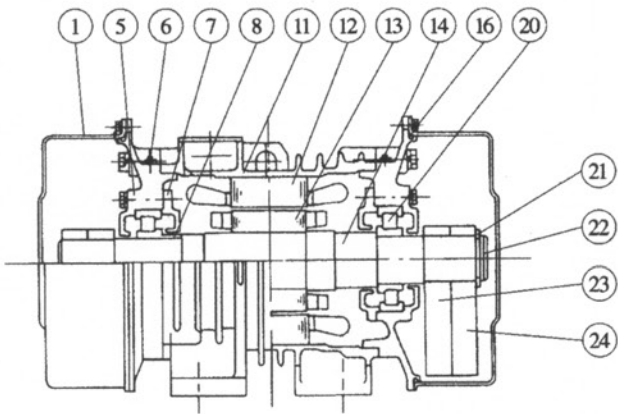

FIGURE 6

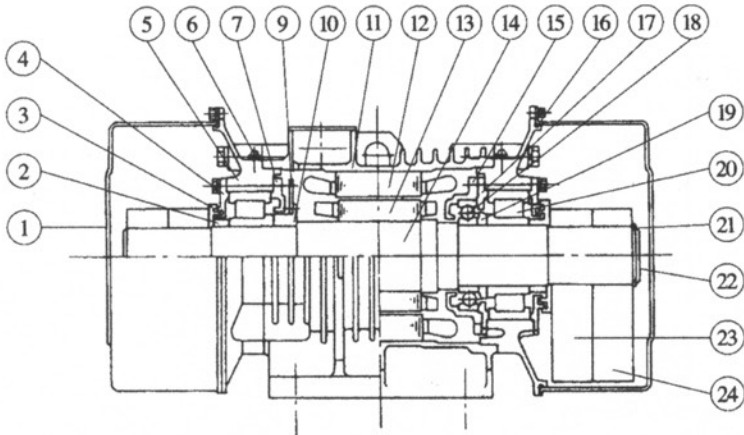

FIGURE 7

No.	Part Name
1	Weight Cover
2	Dust Collar
3	Dust Cover
4	Bearing Cover
5	Bracket
6	Grease Nipple
7	Bearing Cover
8	Collar
9	Grease Stopper
10	Sleeve
11	Frame
12	Stator Core
13	Rotor Core
14	Shaft
15	Housing
16	Seal Ring
17	Thrust Collar
18	Ball Bearing
19	Distance Collar
20	Roller Bearing
21	Snap Ring
22	Scale Plate
23	Fixed Weight
24	Adjustable Weight

PERIODICAL INSPECTION

Interval	Points to Check	Procedures and Criteria
Daily	Load Current	Load current measured with an ammeter should be less than the rated value.
	Bearing Noise	Check bearing noise with or without rod. Bearings should not generate intermittent or metallic noise.
Monthly	Loose Screws	Screws should be tightened to a specific torque.
	Cables	Visually inspect cables. They should not be damaged.
Annually	Insulation resistance of starter coil	Insulation resistance across terminals of a starter coil, measured with a megger, should be 5 (min.).

TROUBLESHOOTING

Phenomena	Causes	Inspection Procedures	Remedies
Vibrator won't start	Two cables of the vibrator or two phases of the coil are broken	Measure the voltage drop across the two phases	Replace the broken cables w rewind the coil
The vibrator moans and does not accelerate	Single phasing	Same as above and check cables for looseness	Same as above or securely connect the cables
	Ambient temperature is too low or there is an excessive amount of grease	Remove the weight covers and rotate the shaft 30 to 50 turns by hand	Adjust the vibrating force to 20% to 30% of the maximum value
Abnormal bearing noise	Damaged raceway surface	Check bearing noise using rod	Replace the bearing
Temperature of the vibrator body is too high	Ambient temperature is too high	Measure ambient temperature	Decrease the ambient temperature to a maximum of 140°F
	A lot of foreign matter has adhered to the vibrator	Check the condition of the foreign matter attached to the vibrator	Carry out dust prevention measures
Thermal relay is tripped	Shortcircuit between phases of the coils	Compare the resistance between phases of the coils	If there is a large difference in resistance between the phases of coils, replace the coils
	Loose screws	Check screws for looseness	Tighten screws
	Abnormal vibration	Ensure that the vibrator rotates in the correct direction and that the vibrator body is free of defects	Correct vibrator rotation direction or repair
	Load is too large	Measure load current	Decrease vibrating force
	Damaged bearing	Rotate the shaft by hand and check that the bearings are not damaged	Replace the bearing



BPS custom engineers and fabricates the following products and more in its 30,000 sq. ft. facility in Brunswick, OH.

- VIBRATORY FEEDERS AND CONVEYORS
- VIBRATORY SCREENERS
- VIBRATORY TABLES
- BULK BAG LOADERS
- BULK BAG UNLOADERS
- CUSTOM ENGINEERED SYSTEMS



1071 Industrial Parkway North
Brunswick, OH 44212
330-220-1440
Fax: 330-220-1447
sales@bpsvibes.com
www.bpsvibes.com